

808 nm High-Power Laser Diode (AL0808T5000)

Features:

Output power 5.0w(CW)
 Variety of stripe width
 Efficient quantum well structure

Application:

Solid-state laser pumping
 Medical usage
 Beacons and Illumination
 Free-space communication
 Infrared light sources



Specifications:

Parameter	Value
	AL808T5000
CW output power (mW)	5000
Peak wavelength (nm)	808 ± 10
Spectral width (nm)	≤ 5
Threshold current (A)	≤ 1100
Operating current (A)	≤ 5200
Operating voltage (V)	≤ 2.2
Slope efficiency (W/A)	≥ 1.0
Beam divergence $\theta_{\perp} \times \theta_{\parallel}$ (deg.)	12/40
Wavelength temperature coefficient (nm/°C)	0.3
Emitting area (μm)	200 × 1
Serial resistance (Ω)	≤ 0.25
Lifetime(h)	10000
Package	TO-3, C-Mount

TO-3 Package(Unit: mm)

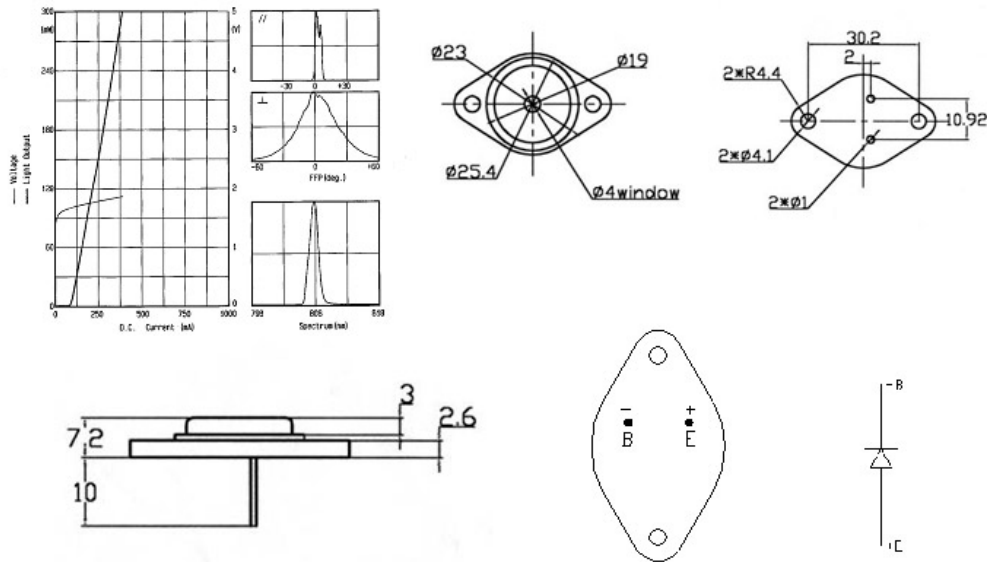

-Mount heat sink: (Unit : mm, Heat sink(+))
C-Mount 1 (C)

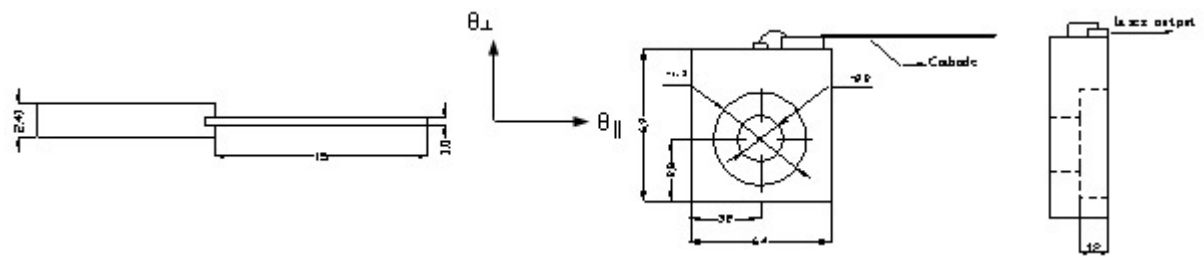

C-Mount 2 (S)

